

L-PSW SERIES

NON-RATED FLUSH ACCESS PANEL WITH PLASTER SURFACES

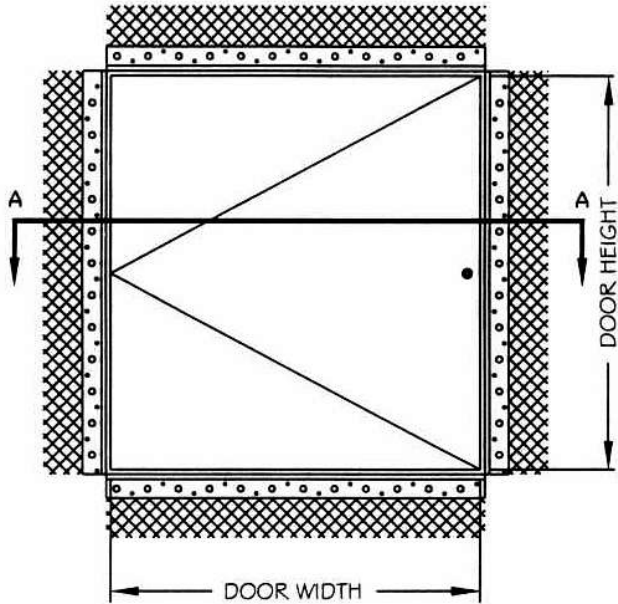

FRONT ELEVATION
NOT TO SCALE

SPECIFICATIONS

- 16 GAUGE (1.520mm) COLD ROLLED STEEL FRAME
- 14 GAUGE (1.900mm) COLD ROLLED STEEL DOOR
- PHOSPHATE DIPPED WITH BAKED ON RUST INHIBITIVE GRAY PRIME FINISH
- 22 GAUGE (.0336mm) GALVANIZED STEEL PLASTER BEAD
- CONCEALED SPRING PIN HINGE
- FLUSH SCREWDRIVER OPERATED CAM LATCH (ADDITIONAL CAMS PROVIDED ON PANELS 18" X 18" AND GREATER IN SIZE)
- FRAMES ARE PROVIDED WITH .25" MOUNTING HOLES

OPTIONS

- q KEY OPERATED CYLINDER LOCK
- q PINNED ALLEN HEAD SECURITY CAM LATCHES
- q PREPARATION FOR 1.125" MORTISE CYLINDER (CYLINDER PROVIDED BY OTHERS OR BY LARSENS)
- q STAINLESS STEEL (TYPE 304) WITH A #4 SATIN POLISH FINISH
- q GALVANIZED BONDERIZED STEEL
- q METAL KNURLED KNOB CAM LATCHES

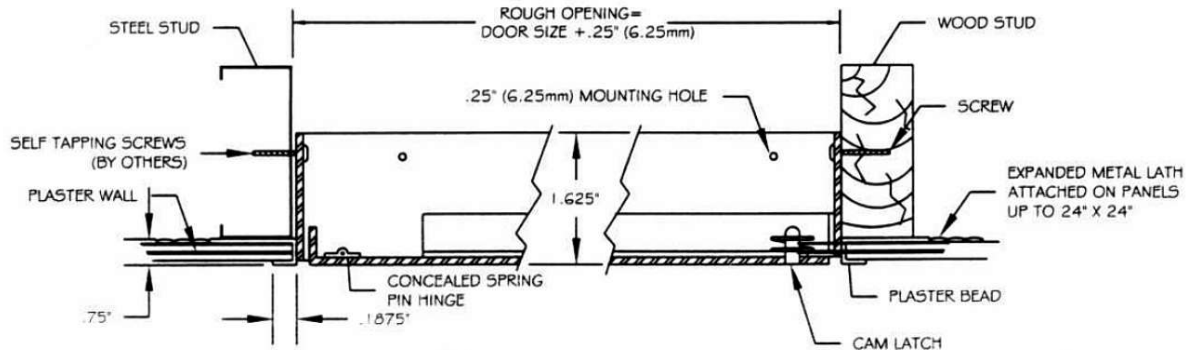

A CUT-THRU SECTION
A NOT TO SCALE

LARSEN'S MANUFACTURING CO.

7421 COMMERCE LANE
MINNEAPOLIS, MN 55432
PHONE: 800-527-7367
FAX: 763-571-6900
www.larsensmfg.com

PROJECT:

CONTRACTOR:

ARCHITECT:

DRAWN BY:

CMR

DATE:

9-1-01

QUANTITY:

TITLE:

L-PSW.DOC



L-PSW – NON-RATED ACCESS PANEL WITH PLASTER CASING BEAD

L-PSW Standard Features:

- Door: 14 gauge (1.90 mm thick) cold rolled steel
- Frame: 16 gauge (1.52 mm thick) cold rolled steel with 22 gauge galvanized plaster casing bead
- Hinge: Concealed spring pin hinge (opens to 175 degrees)
Optional: Continuous piano hinge (see below for details)
- Latch: Screwdriver operated cam latch(es)
Optional: key operated cylinder lock, pinned allen head security cam latch(es), mortise cylinder preparation (cylinder provided by Larsens or others)
- Finish: Phosphate dipped with factory applied prime coat
Optional: galvanized bonderized or stainless steel with #4 polish

L-PSW Specifications:

Model *NP* for non-rated plaster applications. Access panel shall be model L-PSW, size _____ as manufactured by **Larsens Mfg.** of Minneapolis, MN.

Frame shall be 16 gauge cold rolled steel and door shall be 14 gauge. Trim shall be 22 gauge galvanized plaster casing bead. Hinge shall be concealed spring pin hinge that allows door to be removed (non-removable continuous piano type on stainless steel panels and dimensions exceeding 36"). Latch(es) shall be a screwdriver operated cam type (optional: key operated cylinder lock, pinned allen head security cam latch(es), or preparation to receive 1-1/8" mortise cylinder – cylinder provided by Larsens or others). Finish shall be phosphate dipped with factory applied prime coat (optional: galvanized bonderized steel or stainless steel with #4 satin polish finish).

Installation shall be in accordance with manufacturer's instructions. Manufacturer shall guarantee against defects in material and workmanship for a period of one year.

L-PSW Standard Sizes:

<i>Std sizes (in)</i>	<i>Std Sizes (mm)</i>	<i>Weight/Latches</i>	<i>Std Sizes (in)</i>	<i>Std Sizes (mm)</i>	<i>Weight/Latches</i>
06x06	152x152	3/1	20x30	508x762	19/5
08x08	203x203	4/1	22x22	559x559	19/4
10x10	254x254	5/1	22x30	559x762	22/5
12x12	305x305	7/1	24x24	610x610	20/4
12x18	305x457	10/1	24x30	610x762	24/5
12x24	305x610	12/1	24x36	610x914	28/5
14x14	356x356	8/1	24x48*	610x1219	33/6
16x16	406x406	11/1	30x30	762x762	26/5
16x20	406x508	12/2	32x32	813x813	29/5
18x18	457x457	12/2	36x36*	914x914	36/5
18x24	457x610	18/3	36x48*	914x1219	52/7

**Denotes non-removable continuous piano hinge – standard on all stainless steel panels. All units are hinged on the second dimension (height). Rough opening is door size plus ¼"*

Larsens Manufacturing Company 7421 Commerce Lane Minneapolis, MN 55432
 Ph: 800-527-7367 Fax: 763-571-6900
 Web : www.larsensmfg.com