

L-APC SERIES

RECESSED ACCESS PANEL FOR PLASTER SURFACES

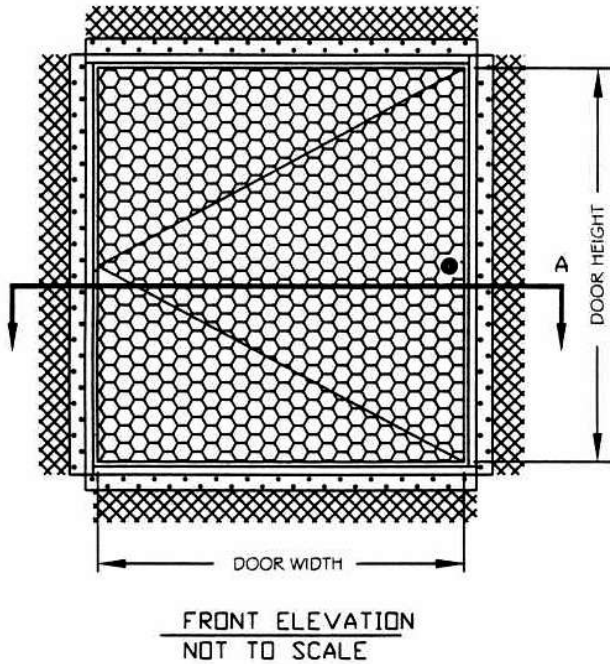

SPECIFICATIONS

- 16 GAUGE (1.520mm) COLD ROLLED STEEL FRAME
- 16 GAUGE (1.520mm) COLD ROLLED STEEL DOOR
- SELF-FURRING 3.4 lb. GALVANIZED STEEL LATH WELDED TO DOOR
- PHOSPHATE DIPPED WITH BAKED ON RUST INHIBITIVE GRAY PRIME FINISH
- 22 GAUGE GALVANIZED STEEL PLASTER BEAD WITH EXPANDED LATH *SEE NOTATION BELOW
- CONCEALED PIVOT ROD HINGE
- SCREWDRIVER OPERATED CAM LATCH WITH STEEL GROMMET WELDED TO DOOR
- FRAMES ARE PROVIDED WITH .25" (6.25mm) MOUNTING HOLES

OPTIONS

- q GALVANIZED BONDERIZED STEEL
- q KEY OPERATED CYLINDER LOCK
- q PREPARATION FOR 1.125" MORTISE CYLINDER (CYLINDER PROVIDED BY OTHERS OR BY LARSENS)

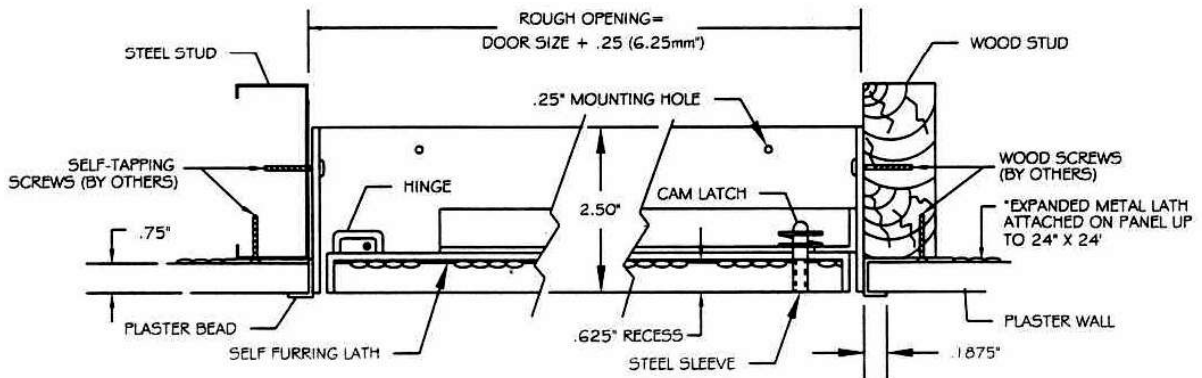

(A) CUT-THRU SECTION
(A) NOT TO SCALE

LARSEN'S MANUFACTURING CO. 7421 COMMERCE LANE MINNEAPOLIS, MN 55432 PHONE: 800-527-7367 FAX: 763-571-6900 www.larsensmfg.com				PROJECT:			
				CONTRACTOR:			
				ARCHITECT:			
DRAWN BY:	DATE:	QUANTITY:	TITLE:				
CMR	9-1-01		L-ACP.DOC				



L-APC — RECESSED ACCESS PANEL FOR PLASTER APPLICATIONS

L-ACP Standard Features:

- Door: 16 gauge (1.52 mm thick) cold rolled steel
- Frame: 16 gauge (1.52 mm thick) cold rolled steel with 22 gauge galvanized plaster casing bead
- Hinge: Concealed pivoting rod hinge
- Latch: Screwdriver cam latch(es)
Optional: key operated cylinder lock or special mortise cylinder preparation to accept 2" cylinder (cylinder provided by Larsens or others)
- Finish: Phosphate dipped with factory applied prime coat
- Pan: 5/8" pan for in-fill of material

L-APC Specifications:

Model L-APC recessed access panel for plaster applications. Access panel shall be model L-APC, size _____ as manufactured by **Larsens Mfg.** of Minneapolis, MN.

Frame shall be 16 gauge cold rolled steel with 22 gauge galvanized plaster casing bead. Door shall be fabricated from 16 gauge cold rolled steel, recessed 5/8" for in-fill of material. Hinge shall be a concealed pivoting rod type. Latch(es) shall be a screwdriver operated cam type (optional: key operated cylinder lock or preparation to receive special 2" mortise cylinder — provided by Larsens or others). Finish shall be phosphate dipped with factory applied prime coat.

Installation shall be in accordance with manufacturer's instructions. Manufacturer shall guarantee against defects in material and workmanship for a period of one year.

L-APC Standard Sizes:

<i>Std sizes (in)</i>	<i>Std Sizes (mm)</i>	<i>Weight/Latches</i>
08x08	152x152	7/1
12x12	254x254	8/1
12x24	305x610	11/2
16x16	406x406	11/1
18x18	457x457	13/2
22x30	559x762	25/2
24x24	610x610	22/2
24x36	610x914	32/3

All units are hinged on the second dimension (height). Rough opening is door size plus 1/4".

Larsens Manufacturing Company 7421 Commerce Lane Minneapolis, MN 55432
 Ph: 800-527-7367 Fax: 763-571-6900
 Web : www.larsensmfg.com